

HOME OFFICE LITE

DYNAMIC SOLUTIONS

SHELVING SYSTEM

FICHA TÉCNICA



ESTRUCTURA

Barras

Estantes

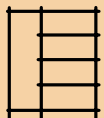

MODELOS

Básicos

Escritorios

Vestidores

Divisores de espacio



COMPLEMENTOS

Paneles interiores

Paneles laterales (interiores)

Paneles exteriores

Armario

Barras de soporte

Cojín

Plecs



DOCUMENTACIÓN



ECODISEÑO

ESTRUCTURA

BARRAS:

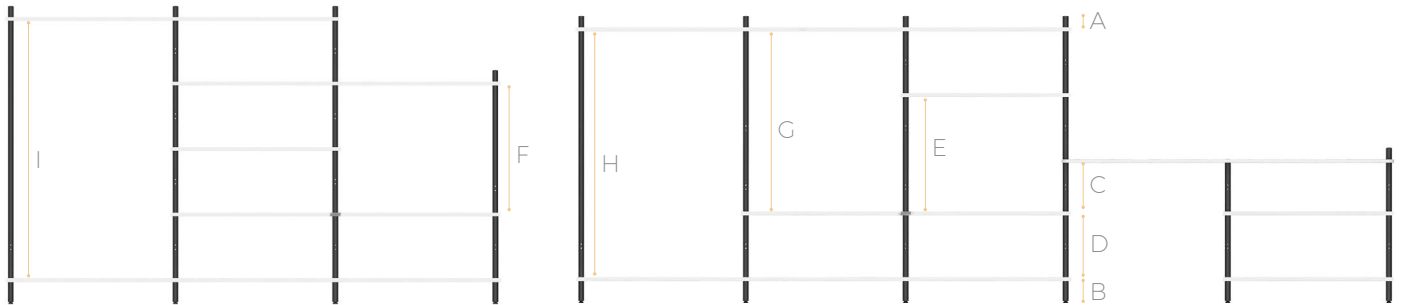

Barras: fabricadas en tubo de acero laminado en frío de $\varnothing 30 \times 2$ mm.

A.	5,6 cm	Barra terminal superior
B.	10 cm	Barra terminal inferior
C.	25 cm	Barra unión
D.	32 cm	Barra unión
E.	58,9 cm	Barra unión
F.	65,9 cm	Barra unión
G.	92,8 cm	Barra unión
H.	126,7 cm	Barra unión
I.	133,7 cm	Barra unión

A. La barra terminal superior: incluye en el extremo superior un tapón embellecedor de polietileno.

B. La barra terminal inferior: incluye en el extremo inferior un regulador con rótula de polipropileno negro (M8 y altura $\pm 1,5$ cm con inclinación de 15°) para ofrecer un mejor asentamiento en el suelo.



Para la unión del conjunto se utilizan casquillos expansores negros de poliamida situados en el interior de las barras, tuercas hexagonales M8 y tornillos DIN 933 M8x45 mm.

Para que todos los agujeros de las barras queden alineados en el montaje se incluye una pieza de metacrilato de 6 mm de espesor que sirve de guía.

ACABADOS:



Negro
RAL 9005



Blanco
RAL 9016



Plata
RAL 9006



Grafito
RAL 7022

ESTRUCTURA

ESTANTES:



Fabricado con tablero aglomerado de partículas de 19 mm de grosor con recubrimiento melamínico de 120g/m² por ambas caras y una densidad de 630 ± 5kg/m³. Los cantos son de ABS de 2 mm de grosor aplicados con cola termofusible y con aristas redondeadas.

A.	88,5 x 42 cm	Estante de 90
B.	130,3 x 42 cm	Estante 90 + 50
C.	172,1 x 42 cm	Estante 90 + 90
D.	172,1 x 60 cm	Estante escritorio



Los estantes se fijan a las barras del conjunto mediante unos agujeros en cada extremo y tornillos DIN 933 M8x45 mm.

ACABADOS:



Negro



Grafito



Blanco



Roble



Acacia
clara



Acacia
oscura



Castaño
claro



Castaño
oscuro

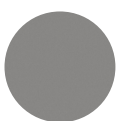

Gris



Azul



Amarillo



Rojo



Naranja



Verde



Verde
turquesa

"MB" - MODELOS BÁSICOS:

SHELVING 90:

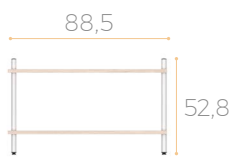

1 NIVEL
"MB1"

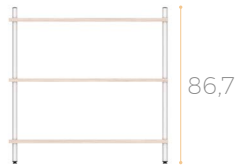

2 NIVELES
"MB2"



3 NIVELES
"MB3"

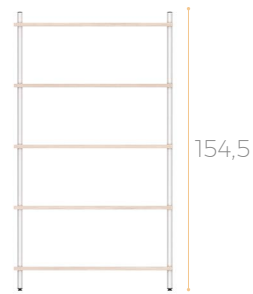

4 NIVELES
"MB4"

SHELVING 90 + 50:

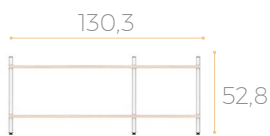

1 NIVEL
"MB5"



2 NIVELES
"MB6"

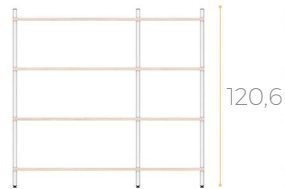

3 NIVELES
"MB7"

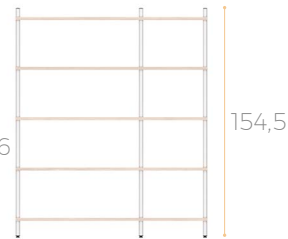

4 NIVELES
"MB8"

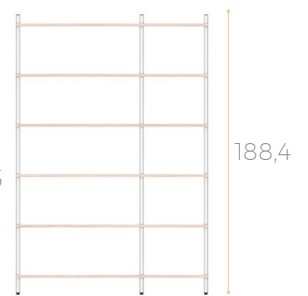

5 NIVELES
"MB9"

SHELVING 90 + 90:



1 NIVEL
"MB10"



2 NIVELES
"MB11"



3 NIVELES
"MB12"

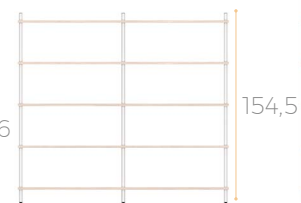

4 NIVELES
"MB13"

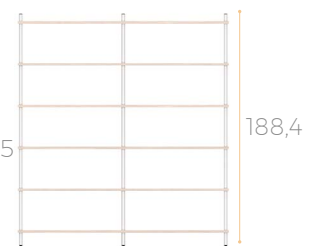

5 NIVELES
"MB14"

SHELVING 90 + 50 + 50 + 90:

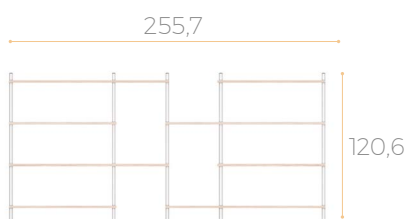

3 NIVELES
"MB15"

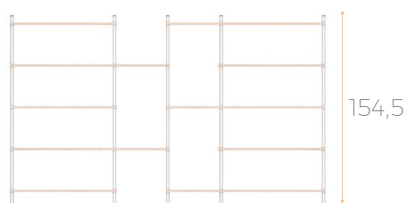

4 NIVELES
"MB16"

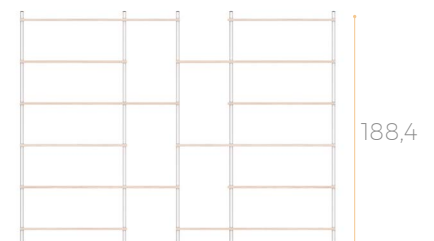

5 NIVELES
"MB17"

"ME" - MODELOS ESCRITORIO:

ESTÁNDAR:

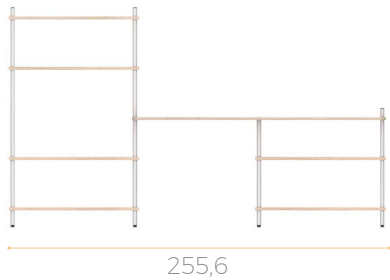

"ME1" SHELVING 90 + ESCRITORIO

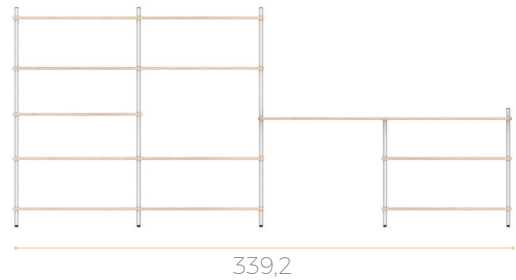

"ME2" SHELVING 90 + 90 + ESCRITORIO

PERCHERO + ESCRITORIO:

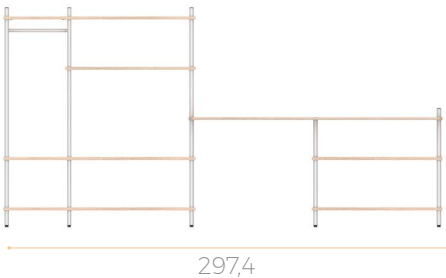

"ME3" PERCHERO 50 + SHELVING 90 + ESCRITORIO

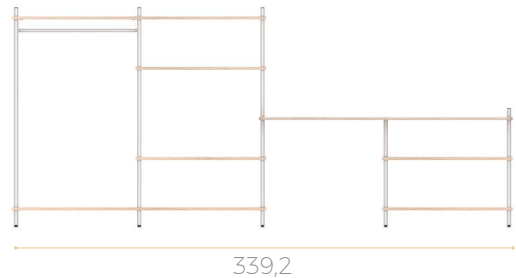

"ME4" PERCHERO 90 + SHELVING 90 + ESCRITORIO

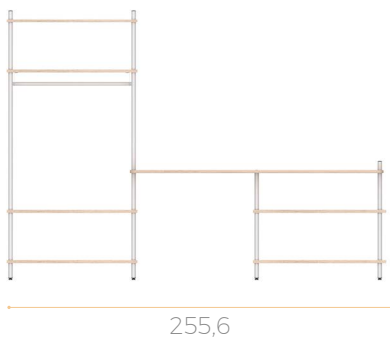

"ME5" PERCHERO 90 + ESCRITORIO

PERCHERO + ESCRITORIO + BANQUETA:

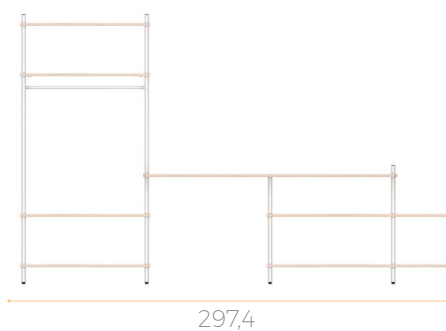

"ME6" PERCHERO 90 + ESCRITORIO + BANQUETA

"MV" - MODELOS VESTIDORES:

ESTÁNDAR:

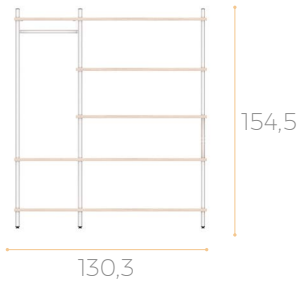

"MV1" PERCHERO 50 +
SHELVING 90

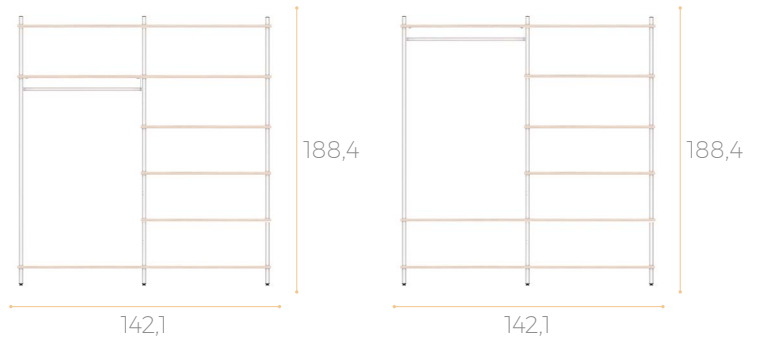

"MV2" PERCHERO 90 + SHELVING 90

VESTIDOR + BANQUETA:

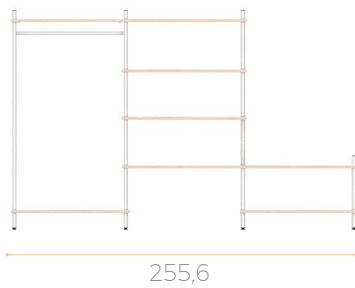

"MV3" PERCHERO 90 + SHELVING 90
+ BANQUETA

“MD” - MODELOS DIVISOR:

“MD220” - PACK MULTIPOSICIÓN - Posibles montajes :

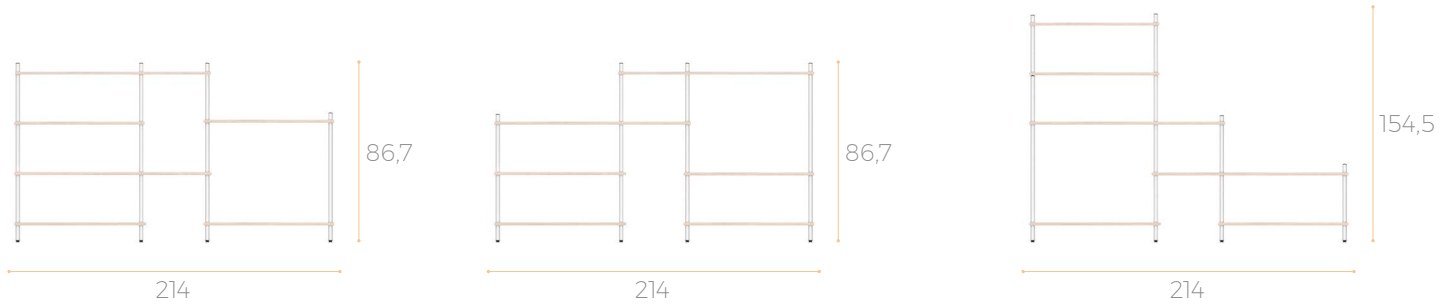

“MD260” - PACK MULTIPOSICIÓN - Posibles montajes :

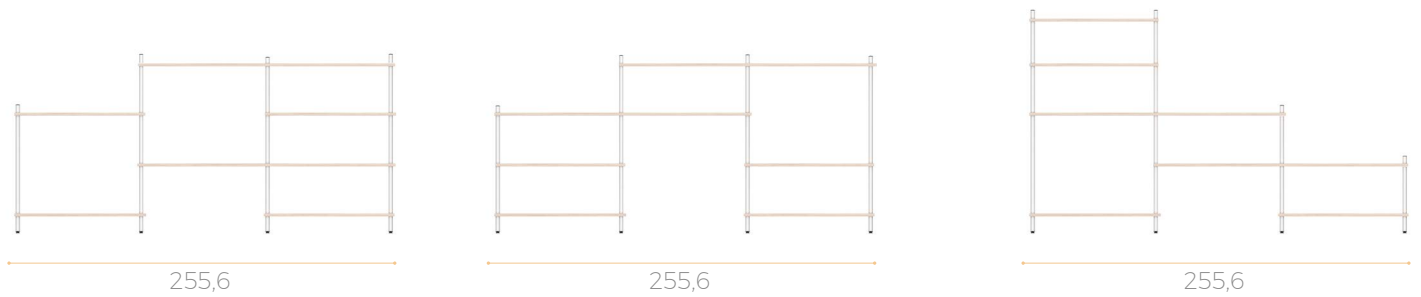

“MD340” - PACK MULTIPOSICIÓN - Posibles montajes :

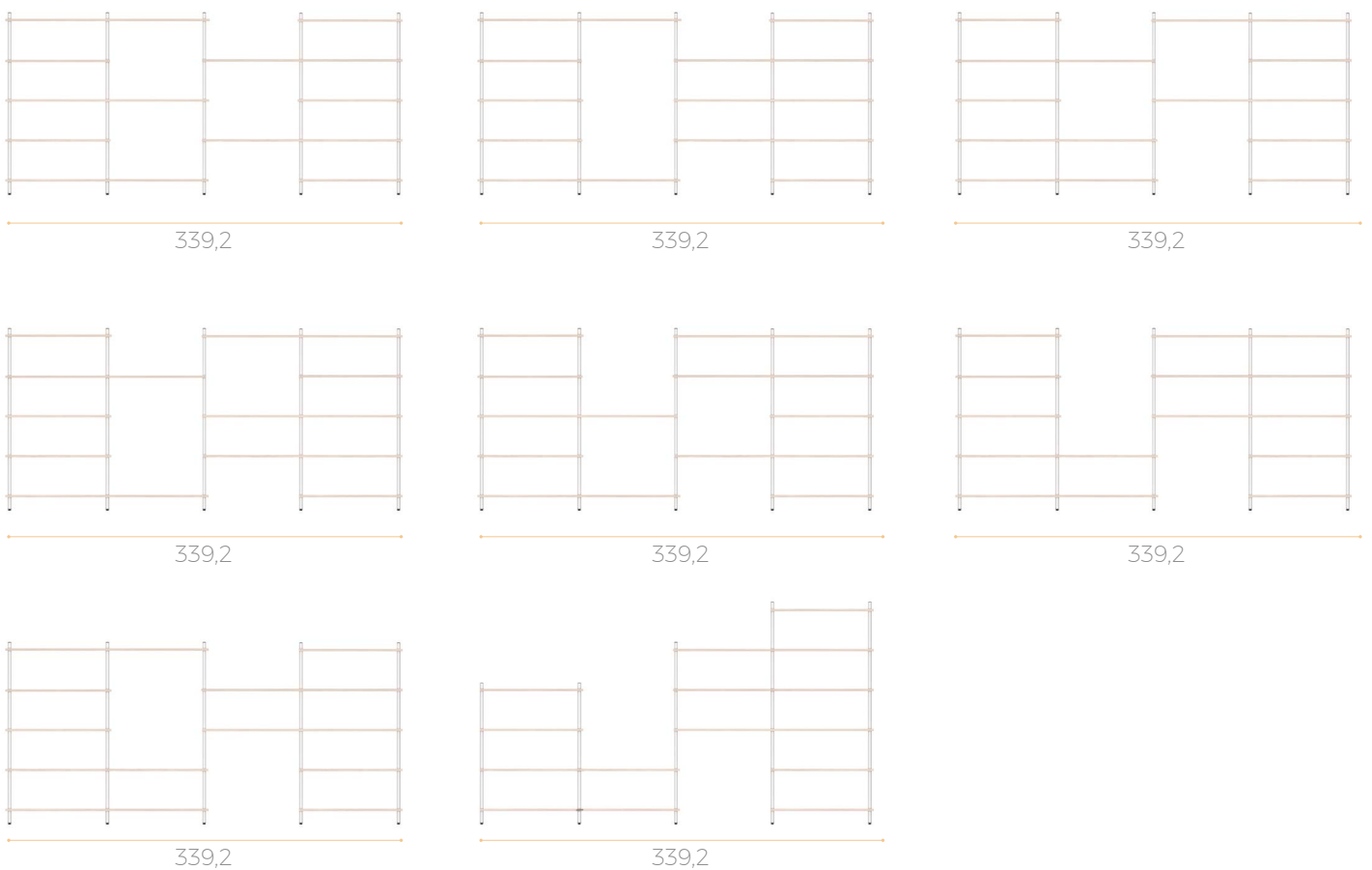

COMPLEMENTOS:

PANEL INTERIOR ACÚSTICO DE 50 y 90:



Fabricado con panel microporoso de base PET 100% reciclado de densidad 2,40 (kg/m²)^{±10} y espesor 8^{±0,6} mm.

Absorción acústica de 0,45 (MH) αw.

ACABADOS:



Gris claro



Gris oscuro



Grafito



Negro



Beige



Marrón



Los paneles se fijan a la estructura metálica mediante **2 o 4 pinzas** negras de polipropileno con fibra de vidrio, una tuerca hexagonal y un tornillo DIN 912 M5x14 zincado blanco.



Se colocan **entre estantes**.

MEDIDAS (cm):



H.133,6
4 NIVELES

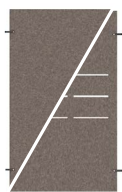

H.126,6
PERCHERO



H.99,7
3 NIVELES



H.92,7
ESTANTERÍA
CON PERCHERO

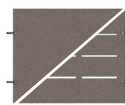

H.65,8
2 NIVELES

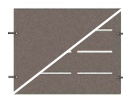

H.58,8
ESTANTERÍA



H.31,9
1 NIVEL



H.24,9
ESCRITORIO



H.133,6
4 NIVELES



H.126,6
PERCHERO



H.65,8
2 NIVELES



H.31,9
1 NIVEL

Los paneles con ranuras sirven para colgar

COMPLEMENTOS:

PANEL INTERIOR METACRILATO DE 50 y 90:



Fabricadas en lámina de metacrilato extruido satinado (PMMA) de 3 mm de espesor.

ACABADOS:



Naranja



Azul



Translúcido



Los paneles se fijan a la estructura metálica mediante **2 o 4 pinzas** negras de polipropileno con fibra de vidrio, una tuerca hexagonal y un tornillo DIN 912 M5x14 zincado blanco.



Se colocan **entre estantes**.

MEDIDAS (cm):



H.133,6
4 NIVELES



H.126,6
PERCHERO



H.99,7
3 NIVELES

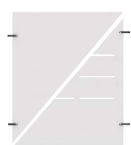

H.92,7
ESTANTERÍA
CON PERCHERO



H.65,8
2 NIVELES



H.58,8
ESTANTERÍA



H.31,9
1 NIVEL

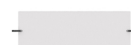

H.24,9
ESCRITORIO



H.133,6
4 NIVELES



H.126,6
PERCHERO



H.65,8
2 NIVELES



H.31,9
1 NIVEL

Los paneles con ranuras sirven para colgar

COMPLEMENTOS:

PANEL INTERIOR PIZARRA DE 90:



Está compuesto por dos paneles:

- Un panel en la **parte trasera**: fabricado con chapa de acero laminada en frío de 1 mm pintada con pintura epoxi blanco (RAL 9016), plata (RAL 9006), grafito (RAL 7022) o negro (RAL 9005).
- Un panel en la **parte delantera**: pizarra blanca que va imantada al panel trasero metálico.

Apta para imanes y escritura con rotulador, borrado en seco.



Los paneles se fijan a la estructura metálica mediante **2 o 4 pinzas** negras de polipropileno con fibra de vidrio, una tuerca hexagonal y un tornillo DIN 912 M5x14 zincado blanco.



Se colocan **entre estantes**.

MEDIDAS (cm):

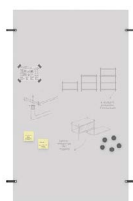

H.133,6
4 NIVELES

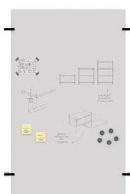

H.126,6
PERCHERO

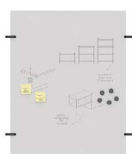

H.99,7
3 NIVELES

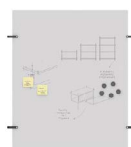

H.92,7
ESTANTERÍA
CON PERCHERO

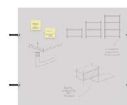

H.65,8
2 NIVELES

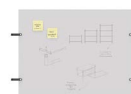

H.58,8
ESTANTERÍA



H.133,6
4 NIVELES



H.126,6
PERCHERO

COMPLEMENTOS:

PANEL INTERIOR ACÚSTICO LATERAL DE 32:



Fabricado con panel microporoso de base PET 100% reciclado de densidad 2,40 (kg/m²)^{±10} y espesor 8^{±0,6} mm.

Absorción acústica de 0,45 (MH) αw.

ACABADOS:



Gris claro



Gris oscuro



Grafito



Negro



Beige



Marrón



Los paneles se fijan a la estructura metálica mediante **2 o 4 pinzas** negras de polipropileno con fibra de vidrio, una tuerca hexagonal y un tornillo DIN 912 M5x14 zincado blanco.



Se colocan **entre estantes**.

MEDIDAS (cm):



H.133,6
4 NIVELES



H.126,6
PERCHERO



H.92,7
ESTANTERÍA
CON PERCHERO



H.65,8
2 NIVELES



H.58,8
ESTANTERÍA



H.31,9
1 NIVEL

COMPLEMENTOS:

PANEL INTERIOR METACRILATO LATERAL DE 32:



Fabricadas en lámina de metacrilato extruido satinado (PMMA) de 3 mm de espesor.

ACABADOS:



Naranja



Azul



Translúcido



Los paneles se fijan a la estructura metálica mediante **2 o 4 pinzas** negras de polipropileno con fibra de vidrio, una tuerca hexagonal y un tornillo DIN 912 M5x14 zincado blanco.



Se colocan **entre estantes**.

MEDIDAS (cm):



H.133,6
4 NIVELES



H.126,6
PERCHERO



H.92,7
ESTANTERÍA
CON PERCHERO



H.65,8
2 NIVELES



H.58,8
ESTANTERÍA



H.31,9
1 NIVEL

COMPLEMENTOS:

PANEL INTERIOR PIZARRA LATERAL DE 32:



Está compuesto por dos paneles:

- Un panel en la **parte trasera**: fabricado con chapa de acero laminada en frío de 1 mm pintada con pintura epoxi blanco (RAL 9016), plata (RAL 9006), grafito (RAL 7022) o negro (RAL 9005).
- Un panel en la **parte delantera**: pizarra blanca que va imantada al panel trasero metálico.

Apta para imanes y escritura con rotulador, borrado en seco.



Los paneles se fijan a la estructura metálica mediante **2 o 4 pinzas** negras de polipropileno con fibra de vidrio, una tuerca hexagonal y un tornillo DIN 912 M5x14 zincado blanco.



Se colocan **entre estantes**.

MEDIDAS (cm):



H.133,6
4 NIVELES



H.65,8
2 NIVELES



H.31,9
1 NIVEL

COMPLEMENTOS:

PANEL EXTERIOR ACÚSTICO:



Fabricado con panel microporoso de base PET 100% reciclado de densidad 2,40 (kg/m²)^{±10} y espesor 8^{±0,6} mm.

Absorción acústica de 0,45 (MH) αw.

ACABADOS:



Gris claro



Gris oscuro



Grafito



Negro



Beige



Marrón



Los paneles se fijan a la estructura metálica mediante **2 herrajes superiores negros** fabricados en chapa de acero laminada en frío de 3 mm de grosor, tornillos embellecedores de M6x12 zincado blanco y **abrazaderas** de metacrilato transparente.



Se colocan **en la parte exterior de los estantes.**

MEDIDAS (cm):



H.173,4
5 NIVELES



H.139,4
4 NIVELES



H.132,4
ESTANTERÍA



H.105,5
3 NIVELES



H.98,5
ESTANTERÍA

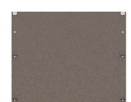

H.71,6
2 NIVELES

COMPLEMENTOS:

PANEL EXTERIOR PIZARRA:



Está compuesto por dos paneles:

- Un panel en la **parte trasera**: fabricado con chapa de acero laminada en frío de 1 mm pintada con pintura epoxi blanco (RAL 9016), plata (RAL 9006), grafito (RAL 7022) o negro (RAL 9005).
- Un panel en la **parte delantera**: pizarra blanca que va imantada al panel trasero metálico.

Apta para imanes y escritura con rotulador, borrado en seco.



Los paneles se fijan a la estructura metálica mediante **2 herrajes superiores negros** fabricados en chapa de acero laminada en frío de 3 mm, tornillos embellecedores de M6x12 zinc. blanco y **abrazaderas** de metacrilato transparente.



Se colocan **en la parte exterior de los estantes**.

MEDIDAS (cm):

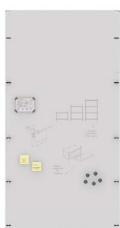

H.173,4
5 NIVELES

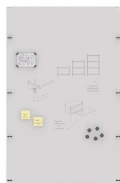

H.139,4
4 NIVELES

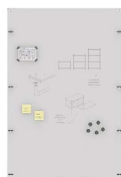

H.132,4
ESTANTERÍA

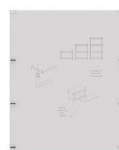

H.105,5
3 NIVELES

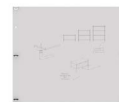

H.98,5
ESTANTERÍA



H.71,6
2 NIVELES



H.71,6
2 NIVELES

COMPLEMENTOS:

ARMARIO:

Cuerpo del armario: compuesto por el sobre, el bajo, dos laterales y trasera.

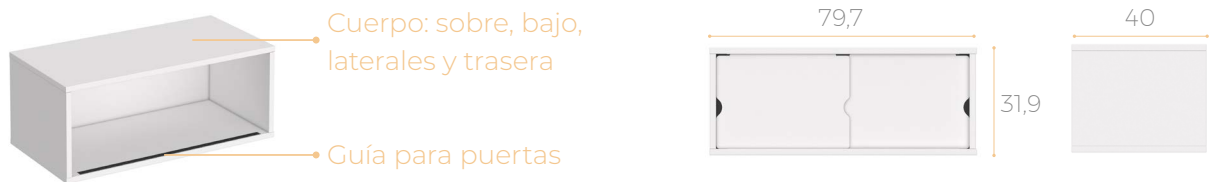

Fabricado con tablero aglomerado de partículas de 19 mm de grosor con recubrimiento melamínico de 120g/m² por ambas caras y una densidad de 630 ± 5kg/m³. Los cantos son de ABS de 2 mm de grosor aplicados con cola termofusible y con aristas redondeadas.



El ensamblaje del conjunto se realiza mediante clavijas, pernos auto-expandibles y excéntricas.



El ensamblaje del armario con las barras de la estructura se realiza con dos arandelas fabricadas en polipropileno gris, dos tornillos DIN 7380 M4x35mm y dos tuercas de unión.

El sobre y el bajo disponen de una **guía** negra de polipropileno para las puertas correderas.

ACABADOS:



Negro



Grafito



Blanco



Roble



Acacia clara



Acacia oscura



Castaño claro



Castaño oscuro

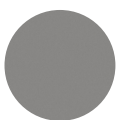

Gris



Azul



Amarillo



Rojo



Naranja



Verde



Verde turquesa

COMPLEMENTOS:

ARMARIO:



Puertas correderas: fabricadas en lámina de metacrilato extruido satinado (PMMA) de 3 mm de espesor.



Las puertas de metacriato se encajan en las guías de la tapa y el bajo del armario sin la necesidad de usar herramientas ni herrajes.

ACABADOS:



Naranja



Azul



Translúcido

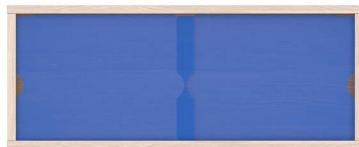
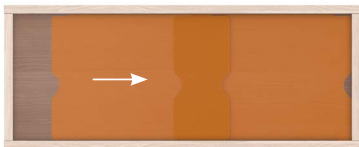

Se coloca **entre estantes**.



COMPLEMENTOS:

BARRAS DE SOPORTE:



Barra de soporte lateral 340 mm



Barra de soporte central 814 mm



Barra de soporte central 414 mm

Barras: fabricadas en tubo de acero laminado en frío de $\varnothing 22 \times 2$ mm.

En cada extremo va soldada una pletina con rosca de 3 mm de espesor.

Se utilizan para prevenir la caída de objetos y complementan la estabilidad del conjunto.



La unión de la barra con la estructura se realiza mediante tornillos DIN 7380 M4x35 zincados blancos.



Se pueden colocar en ambas caras.

Se colocan **entre estantes**.

ACABADOS:



Negro
RAL 9005



Blanco
RAL 9016



Plata
RAL 9006



Grafito
RAL 7022

COMPLEMENTOS:

COJÍN:



Fabricado con tablero aglomerado de partículas de 18 mm de grosor y espuma flexible de poliuretano de espesor 1 cm, densidad 52 Kg/m³.

Se puede tapizar con cualquier tapizado del muestrario de telas excepto EVOLVE.



La unión del cojín con los estantes se realiza mediante cinta adhesiva de doble cara.

MEDIDAS (cm):

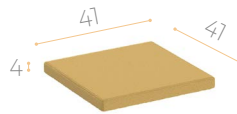
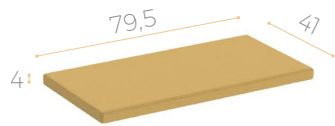

COMPLEMENTOS:

PLECS:



Realizados con panel microporoso de base PET 100% reciclado de densidad 0,60 (kg/m²)^{±10} y espesor 3 mm.

Fabricados mediante *digital cutting*, plegado y fijado con cola termofusible.



Se cuelgan de los paneles ranurados mediante ganchos de metacrilato transparente de 6mm de espesor.

También pueden ir directamente sobre cualquier superficie plana.



Lapicero doble



Lapicero



Clasificador



Bandeja



Estante librería

ACABADOS:



Gris claro



Gris oscuro



Grafito



Negro



Beige



Marrón

MANTENIMIENTO



Limpiar el mueble y sus elementos con un paño suave húmedo y detergente neutro.

RECICLABILIDAD Y TOXICIDAD

Este mueble no contiene ningún producto tóxico y sus componentes son reciclables.



Para obtener más información, consultar en la fábrica.